



Flexibility, innovation and safety for your work

## STAINLESS STEEL 360° SWIVEL CRANE MODEL 01M3AISI



The counterbalanced crane 01M3AISI represents the most cost-effective and flexible solution for lifting and transporting loads whereas a high resistance to corrosion is requested. The cleanability of stainless steel makes it the first choice in hospitals, kitchens, food and pharmaceutical processing facilities. Thanks to its compact dimensions the crane 01M3AISI offers a great maneuverability even at full load and can be moved effortlessly in confined spaces. All components are made in Italy to ensure the highest construction quality and the absence of defects.

**CERTIFICATION AND COMPLIANCE WITH REGULATIONS FOR THE PROTECTION AND SAFETY IN THE WORKPLACE**

## 01m3aisi

**CAPACITY 300 KG**

**COUNTERBALANCED SWIVEL CRANE HYDRAULIC LEVER CONTROLLED FAST LIFT DOUBLE ACTION PUMP – FINE CONTROL DESCENT KNOB**

The crane 01M3AISI is equipped with a lever controlled fast and lightweight lift double action pump . The control descent knob make it possible to adjust the descent speed. The arm is extendable in 4 positions and an optional arm extension is available to get a maximum outreach of 1270 mm.

**The model 01M3AISI being a crane with manual lifting does not require a third-party certification according to current legislation or obligation of periodic checks.**

Technical data	UM	01M3AISI
Weight	[kg]	400
Max capacity	[kg]	300
Max pressure	[bar]	50
Tank capacity	[Liters]	2
Cylinder stroke	[mm]	470

**The hydraulic system is equipped with a lock valve that prevents the load from falling in case of accidental breakage of the pipes and a rough valve that prevents overloading of the crane.**

This crane is equipped with 2 high-capacity pivoting wheels with bumper mounts and parking brakes and with 2 fixed front wheels with bearings. Swivel hook type. Rotating Jib arm with 8 locking positions.

CAPACITY AND DIMENSIONS WITH STANDARD JIB ARM		
POS.	Length	Capacity
	[mm]	01M3AISI [kg]
1	365	300
2	500	250
3	635	200
4	770	150

CAPACITY WITH OPTIONAL EXTENDED JIB ARM		
POS.	Length	Capacity
	[mm]	01M3AISI [kg]
1	865	130
2	1000	115
3	1135	100
4	1270	85



- **FRAME AND COMPONENTS IN AISI304.**
- **PUMP AND TANK IN AISI316.**
- **PAINTED STEEL SLEWING RING WITH STAINLESS STEEL AISI304 PROTECTIVE CAP**

**STANDARD EXTENSION**

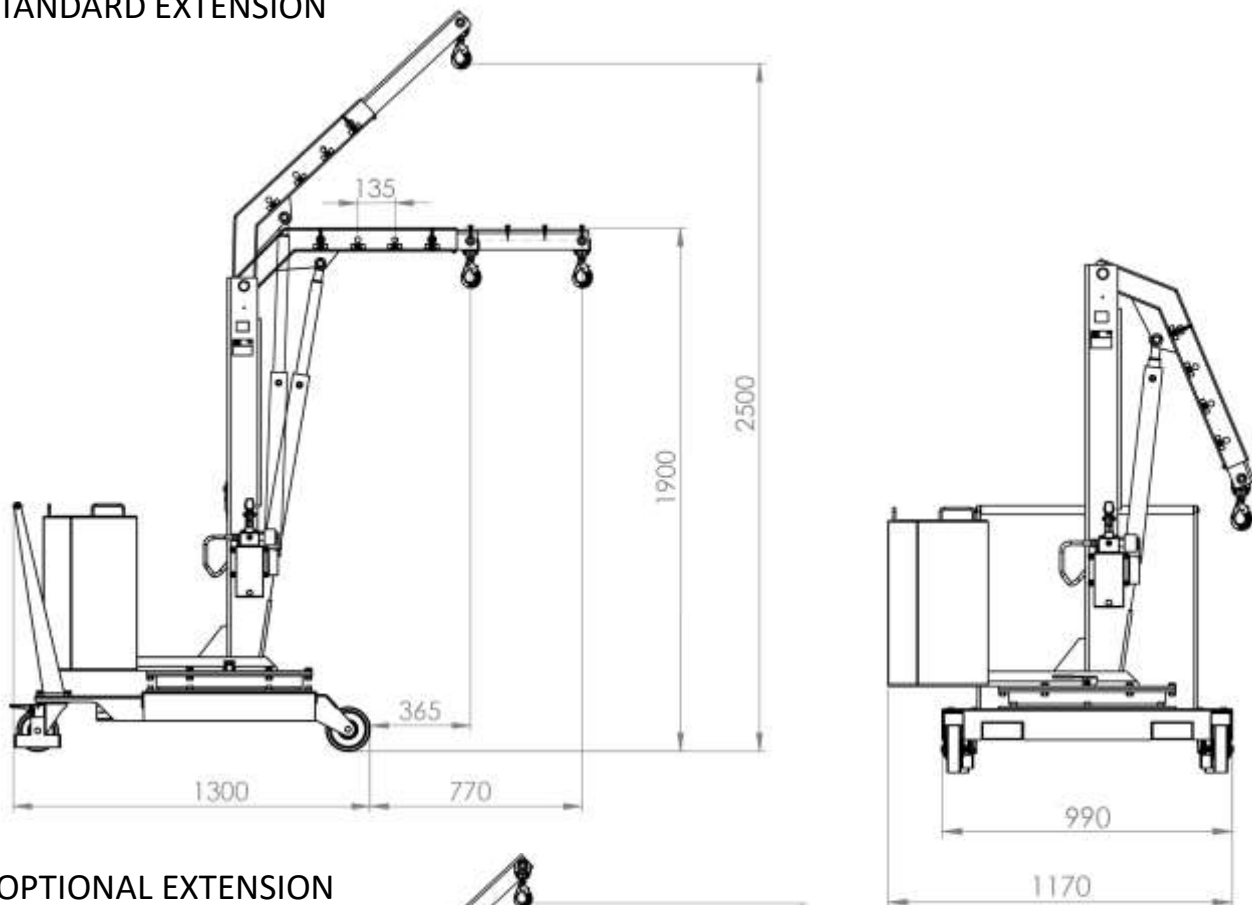

**OPTIONAL EXTENSION**

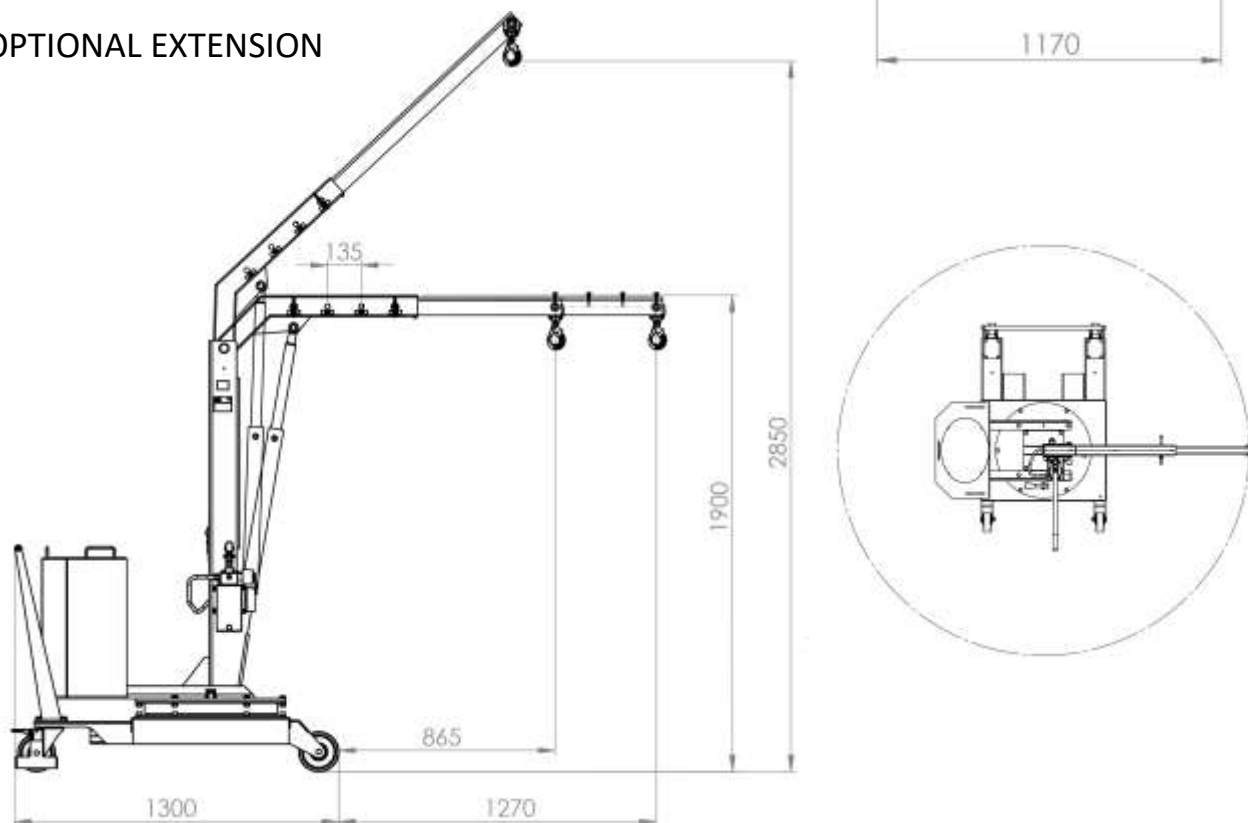



Flexibility, innovation and safety for your work

**A COMPLETE RANGE  
OF COUNTERBALANCED 360° SWIVEL CRANES FOR ANY APPLICATION  
SPECIAL CRANES AND CUSTOM PROJECTS ON DEMAND**

**IN COMPLIANCE WITH SAFETY REGULATIONS  
TO ENSURE YOUR PRODUCTIVITY**

